

# GRAPHICS/PRINT/SIGN  
**GPS**  
**2020**  
**RATECARD**  
**POPU**  
**ACTIVATION**  
29 OCT-1 NOV 2020  
📍 EASTGATE SHOPPING CENTRE

. . . . .  
. . . . .  
. . . . .  
• **STAND SALES**  
• **Dyelan Copeland**  
• **C/** +27 (0) 83 300 3509    **F/** +27 (0) 11 450 1097  
• **T/** +27 (0) 11 450 1650    **E/** Dyelan@PracticalPublishing.co.za

- **NEW Business Opportunities**
- **SHOWCASE Start-up Solutions**
- **SHOWCASE at the NEW business Activation, the Graphics, Print & Signage activation.**

Showcase affordable start-up business opportunities in the world of graphics, signage, digital printing, branding, T-shirt printing, vehicle graphics, laser engraving and more.

We want to inspire visitors to be their own boss and see graphics, print and sign opportunities at the Eastgate PopUp Activation



// VENUE	<b>Eastgate Shopping Centre</b>
COURT	Strelitzia Court, Entrance 6
Activation TIMES	<b>29 October-1 November:</b> Friday 09h00-21h00 Saturday 09h00-18h00 Sunday 09h00-18h00
BUILD-UP	28 October 19h00 - 21h00 29 October 07h00 - 09h00
BREAK DOWN	1 November 18h00 - Once the mall is closed
RATE*	<b>R12 990</b> per 2m X 2m ex VAT
INCLUDES	1 X 2m Shell Scheme (No branding) <ul style="list-style-type: none"> <li>• 1 x LED long arm spotlight</li> <li>• 1 x 15amp 220v standard plug</li> <li>• 4sqm carpets (charcoal)</li> <li>• 1 x company name</li> </ul>
ADDITIONAL	<ul style="list-style-type: none"> <li>• Branded Prints</li> <li>• Furniture</li> <li>• Additional Electricity</li> </ul>
<b>PAYMENT</b>	<ul style="list-style-type: none"> <li>• Stand will only be confirmed once the contract has been signed.</li> <li>• A 50% deposit is required on booking.</li> </ul>

PLATINUM SPONSOR:



**STAND SALES**

**Dyelan Copeland**

**C/** +27 (0) 83 300 3509

**T/** +27 (0) 11 450 1650

**F/** +27 (0) 11 450 1097

**E/** Dyelan@africaprint.com

## VENUE INFORMATION

### Access & Parking //

- Strelitzia Court is near entrance 6
- The open parking opposite entrance 6 is free (Opposite the Mega Mica)
- Undercover Parking - Single exit tickets can be ordered from the organisers at R35 per day.

### Security //

We will have security guards for the duration of the Activation. Please be vigilant regarding all personal items, particularly cellphones, bags, laptops. Don't have them on the stand or keep these locked away at all times in a lockable cupboard which can be ordered.

### Staff Roster //

The Pop-Up Activation is a brand new concept. It is 3 days long and the shopping centre hours are below. We strongly recommend a roster for your crew manning the stand.

### Trading Hours //

Monday - Thursday 09h00-19h00

Friday 09h00-21h00

Saturday 09h00-18h00

Sunday 09h00-18h00

Activation TIMES

## DEMOGRAPHIC OVERVIEW

# 51 439

Ave. Daily Visitors

Source: TGISA 2016 C 15284  
Adult Population; Syenap

### // LSM PROFILE

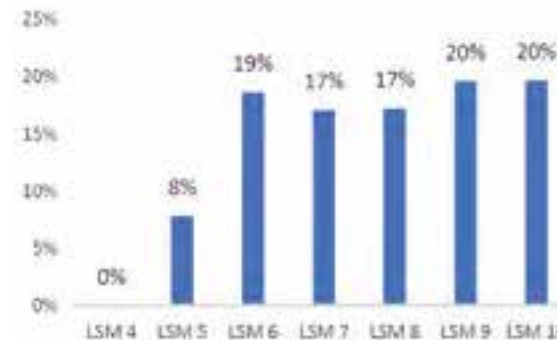

### // GENDER



### // AGE GROUP

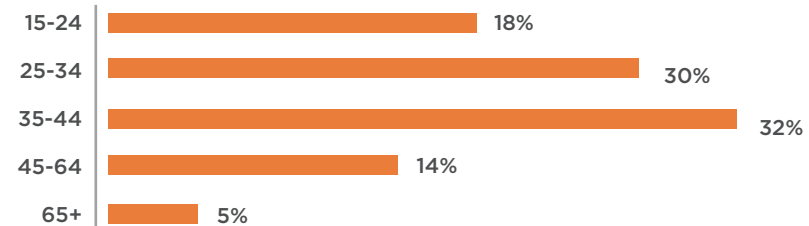

PLATINUM SPONSOR:



### STAND SALES

Dyelan Copeland

C/ +27 (0) 83 300 3509

T/ +27 (0) 11 450 1650

F/ +27 (0) 11 450 1097

E/ Dyelan@africaprint.com

# SHELL SCHEME PACKAGES

Company Name: \_\_\_\_\_

4Sqm



## Graphics Optional

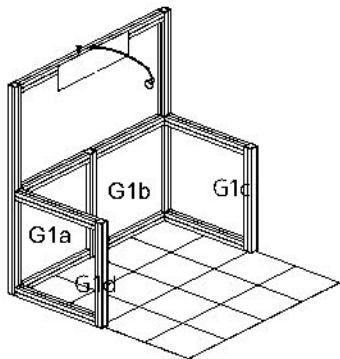

- G1a** R295,00
- G1a** R295,00
- G1c** R295,00
- G1d** R295,00

## Optional

- Asteroid barstool White-FB1001A** R395,00
- Smart Brochure Holder-FD002B** R580,00
- Small Dustbin FM004** R85,00
- Lockable Cupboard CP905** R780,00
- Cocktail Table Aluminium-FT2001** R660,00
- Glass Top Counter-FD005** R1030,00
- Single Tall Show case-FD007** R1580,00
- Plinth-FP903C 500mm(w) x 500mm(d) x 1000mm(h)** R345,00

## Distribution Boards

- Single Phase 30amp DB with 15amp plug on DB R1 575.00
- Three Phase 30amp DB with 15amp plug on DB R2 305.00
- Three Phase 60amp DB only R4 820.00
- 15amp Plug R270.00

## Additional Security

- Day Shift (12hrs) R625.00 2<sup>nd</sup>  3<sup>rd</sup>  4<sup>th</sup>  5<sup>th</sup>
- Night Shift (15hrs) R780.00 1<sup>st</sup>  2<sup>nd</sup>  3<sup>rd</sup>  4<sup>th</sup>

All prices exclude VAT



# SHELL SCHEME PACKAGES

Company Name: \_\_\_\_\_

8Sqm

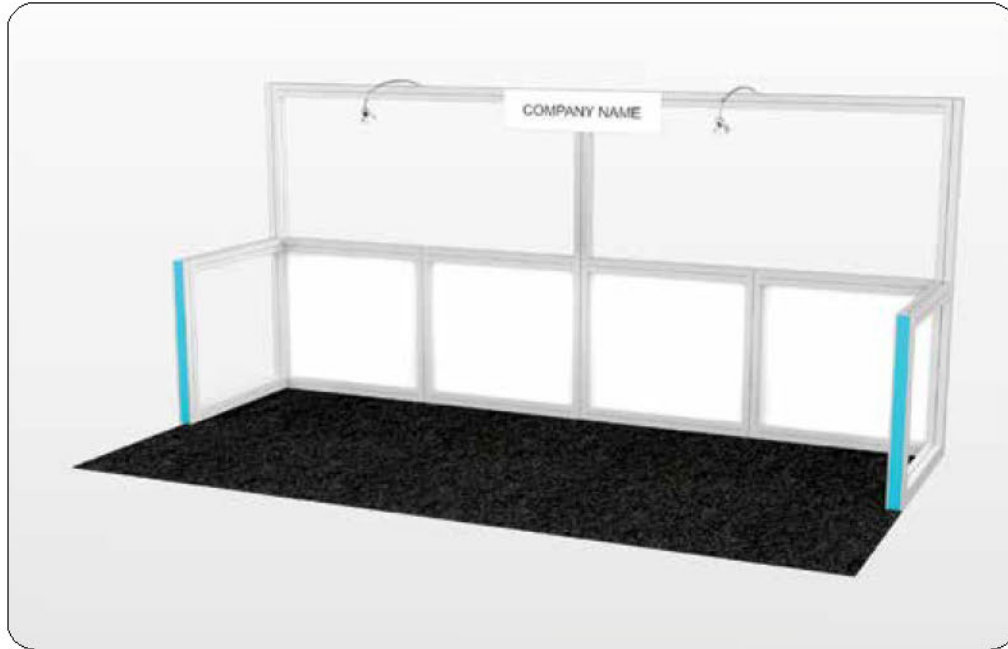

## Graphics Optional

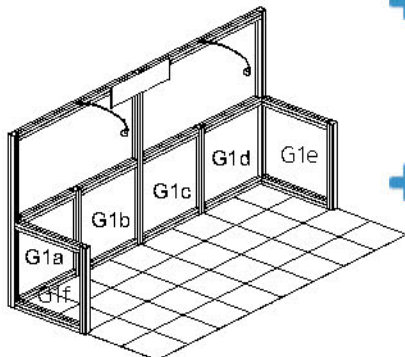

- + R295,00  
**G1a**  
923X853
- + R295,00  
**G1b**  
923X853
- + R295,00  
**G1c**  
923X853
- + R295,00  
**G1d**  
923X853
- + R295,00  
**G1e**  
923X853
- + R295,00  
**G1f**  
923X853

## Optional

- +  Asteroid barstool White-FB1001A  
**R395,00**
- +  Smart Brochure Holder-FD002B  
**R580,00**
- +  Small Dustbin FM004  
**R85,00**
- +  Lockable Cupboard CP905  
**R780,00**
- +  Cocktail Table Aluminium-FT2001  
**R660,00**
- +  Glass Top Counter-FD005  
**R1030,00**
- +  Single Tall Show case-FD007  
**R1580,00**
- +  Plinth-FP903C 500mm(w) x 500mm(d) x 1000mm(h)  
**R345,00**

## Distribution Boards

- Single Phase 30amp DB with 15amp plug on DB **R1 575.00**
- Three Phase 30amp DB with 15amp plug on DB **R2 305.00**
- Three Phase 60amp DB only **R4 820.00**
- 15amp Plug **R270.00**

## Additional Security

- Day Shift (12hrs) **R625.00** 2<sup>nd</sup>  3<sup>rd</sup>  4<sup>th</sup>  5<sup>th</sup>   
06H00-18H00
- Night Shift (15hrs) **R780.00** 1<sup>st</sup>  2<sup>nd</sup>  3<sup>rd</sup>  4<sup>th</sup>   
18H00-09H00

All prices exclude VAT



# SHELL SCHEME PACKAGES

Company Name: \_\_\_\_\_

12Sqm









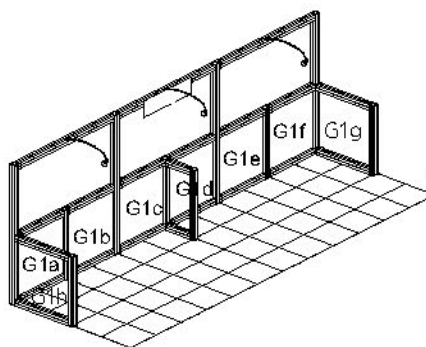

## Optional

-  Asteroid barstool White-FB1001A **R395,00**
-  Smart Brochure Holder-FD002B **R580,00**
-  Small Dustbin FM004 **R85,00**
-  Lockable Cupboard CP905 **R780,00**
-  Cocktail Table Aluminium-FT2001 **R660,00**
-  Glass Top Counter-FD005 **R1030,00**
-  Single Tall Show case-FD007 **R1580,00**
-  Plinth-FP903C 500mm(w) x 500mm(d) x 1000mm(h) **R345,00**

## Graphics Optional



- R295,00**  
 G1a  
923X853
- R295,00**  
 G1b  
923X853
- R295,00**  
 G1c  
923X853
- R295,00**  
 G1d  
923X853
- R295,00**  
 G1e  
923X853
- R295,00**  
 G1f  
923X853
- R295,00**  
 G1g  
923X853
- R295,00**  
 G1h  
923X853

## Distribution Boards

- Single Phase 30amp DB with 15amp plug on DB **R1 575.00**
- Three Phase 30amp DB with 15amp plug on DB **R2 305.00**
- Three Phase 60amp DB only **R4 820.00**
- 15amp Plug **R270.00**

## Additional Security

- Day Shift (12hrs) **R625.00** 2<sup>nd</sup>  3<sup>rd</sup>  4<sup>th</sup>  5<sup>th</sup>
- Night Shift (15hrs) **R780.00** 1<sup>st</sup>  2<sup>nd</sup>  3<sup>rd</sup>  4<sup>th</sup>

All prices exclude VAT



**PLEASE PRINT DETAILS BELOW** This form is to be signed by:

- a.) Organiser and all exhibitors (if you are building your own stand floor space or shell scheme), and
- b.) Organiser and all stand builders & all service providers
- c.) Exhibitors and all stand builders & all service providers

**HEALTH, SAFETY, AND ENVIRONMENTAL REQUIREMENTS AND POLICIES**

**INTRODUCTION**

The health and safety of employees is regulated by the Occupational Health and Safety Act (85 of 1993), which places the prime responsibility for health and safety at work with the employer. For the purposes of this activity the Contractor shall be regarded as the main contractor.

**HEALTH AND SAFETY CONTRACTORS AGREEMENT (In terms of Section 37 (2) of the Occupational Health and Safety Act of 1993) / INDEMNITY / ACCEPTANCE OF RULES & REGULATIONS**

IT IS COMPULSORY THAT THIS FORM IS COMPLETED AND RETURNED TO THE ORGANISERS BY DUE DATE WITHOUT RECEIPT OF THIS FORM, PRACTICAL PUBLISHING RESERVES THE RIGHT TO WITHHOLD ACCESS TO THE PREMISES.

Written agreement between:

PRACTICAL PUBLISHING (ORGANISER) for Graphics Print Sign POPUP Activation (Event) 2005/018213/07 (Company reg number)

And

(Contractor or Exhibitor) \_\_\_\_\_

Company Reg. No \_\_\_\_\_

I, \_\_\_\_\_ ( owner / partner / member / director / manager ) representing \_\_\_\_\_ (Contractor / Exhibitor) do hereby acknowledge that the Contractor / Exhibitor is an employer in its own right, with duties as prescribed in the Occupational Health and Safety Act No. 85 of 1993 as amended, and agree to ensure that all work will be performed, or machinery and plant used, in accordance with the said Act. I furthermore agree to comply, and bind the Contractor/ Exhibitor to comply, with the requirements of POPUP Activation

(Event) as contained in the Events Manual and related legislation concerning the construction of any structure for exhibition purposes for the GPS Regional Activation (Event Name)at: Eastgate Popup Activation 28 October-1 November 2020.

By the signing of this agreement I agree that the Exhibitor / Contractor will provide all related documents to the Exhibitor and Safety Coordinator as mentioned in the Exhibitor Manual, for prior applications to take place and for/to the Local Authority to provide approval for the planned project/activation.

And I, in my representative capacity aforesaid, hereby appoint \_\_\_\_\_ (Sub Contractor/Exhibitor if any or N/A) as the Contractor's / Exhibitor's representative and Responsible person, to supervise all work on the premises of POPUP Activation (Event). Should there be any accidents/injury to any of the Contractor's / Exhibitor's employees, our Workmen's Compensation Commissioner No. is \_\_\_\_\_ (Commissioner for Occupational Injuries and Diseases)

**And I, in my personal capacity and in my representative capacity aforesaid, hereby indemnify Practical Publishing and its employees, agents and representatives, against any liability, loss or proceedings whatsoever, whether arising in common law or by statute, consequent on injury to or the death of any person whomsoever or consequent on loss of or damage to any movable or immovable property, arising out of or caused by or in connection with the execution of all or any work by or on behalf of the Contractor / Exhibitor.**

ID NUMBER		PLACE	
SIGNATURE		DATE	

**I, THE ABOVESTATED REPRESENTATIVE, HEREBY CONFIRM THAT I HAVE READ AND I UNDERSTAND THE VENUE RULES AND REGULATIONS AS LAID OUT ON PAGE 8 OF THE POP UP ACTIVATION RATE CARD AS WELL AS RELEVANT REGULATIONS AND LOCAL BYLAWS, AND I AGREE THAT I WILL ABIDE BY THEM AND THAT I WILL TAKE REASONABLE STEPS TO ENSURE THAT THE EMPLOYEES, AGENTS AND REPRESENTATIVES OF THE CONTRACTOR/EXHIBITOR ARE LIKEWISE FAMILIAR WITH THE RULES AND REGULATIONS AND ABIDE BY THEM.**

SIGNATURE		DATE	
-----------	--	------	--

**THIS FORM, DULY COMPLETED AND SIGNED, MUST BE SUBMITTED TO THE ORGANISERS BEFORE BUILDING OF YOUR STAND STARTS.**

# KIOSK CODE OF CONDUCT

## **Compulsory House Rules**

### **The following is NOT permitted:**

1. Eating and drinking, vaping or making use of any other e-cigarette or tobacco-delivery mechanism, including non-tobacco delivery mechanisms with flavoured or unflavoured, scented or unscented smoke or vapor on the kiosk or stand.
2. Trestle tables and tablecloths.
3. Pull-Up Banners - all signage is to be displayed in a professional manner. All Advertising material and Display Equipment is to be in line with the pre-approved plans submitted prior to the exhibition events.
4. Exhibition material positioned off the Kiosk/Exhibit.
5. Exhibitors standing off the flooring of the kiosk/Exhibit.
6. Harassment of shoppers, including approaching or propositioning them. In the event that an altercation ensues, Exhibitors are advised to contact Centre Management and not handle matters on their own. Under no circumstances will mistreatment of customers, tenants or other exhibitors be tolerated.
7. Promoting of the following:
  - a) Alcohol
  - b) Gambling
  - c) Cigarettes
  - d) Sex or Nudity, including suggestive or promiscuous branding and advertising.
8. Setting up of a kiosk which was not pre-approved or that is not in-line with the submitted plans which detail the exact location, layout and overall appearance.
9. Competition to tenants for example: Clothing or Jewellery.
10. P.A systems or any other apparatus which could cause a nuisance to shoppers, either visually or audibly or affecting any other senses.
11. Solid walling around court.
12. Security is not part of your package. Should security be required for your stand, this will be for your own cost.
13. Hand-written signage or any other illegible or unprofessional signage.
14. The sale or promotion of fake, knock-off, counterfeit or any other goods of questionable quality, repute or origin which may in any way bring into question their authenticity or be damaging to/potentially damaging to the image of the Property and or EBM.

## **Dress Code**

1. All promoters to arrive groomed / presentable throughout the full duration of the exhibition.
2. Professional uniforms are to be worn at all times.

## **Code of conduct:**

- No calling out/ approaching/ harassing of customers walking by.
- If the customer responds; the sales person can approach.
- If the customer does not respond then leave them alone.
- No extended arms holding out scratch cards / samples etc.
- No roaming through the shopping centre.
- Stands to be prepared and ready to trade by 9am each day.
- Stands to be kept neat and tidy at all times.

# KIOSK CODE OF CONDUCT

## **Compulsory House Rules**

**The protocols implemented as of level 4 remain the same throughout all levels and is compulsory for all activations and experiences within the mall. This will be the mandatory health and safety measures post COVID as well.**

**Please ensure your kiosk / exhibition spaces are complaint and equipped with the below PPE (Personal Protective Equipment):**

1. Kiosk staff to wear masks / face shields at all times and to sanitize hands on each new client engagement.
2. 2. Sanitizing station must be available at each kiosk (preferably a foot pedal operated sanitizing system to minimize hand contact).
3. 3. Surfaces and products to be sanitized throughout the day.
4. 4. Barrier tape to be used to enforce 1 m social distancing at all times.
5. 5. Protective Screens / Sneeze Screens to be installed on all kiosks counters to minimize contact.
6. 6. Lastly, a copy of your CIPC certificate and a Compliance letter issued by the relevant property are to be visible on the kiosk at all times.

Kindly note that trade will not be permitted without the above requirements being adhered to and will be monitored weekly.

We thank you for your cooperation and thank you for your efforts in helping to keep our retail environment as safe as possible.